

ELEGANCE

Wall / ceiling fan

Elegance fans can be wall or ceiling mounted and are highly efficient in exhausting air from small and medium size rooms in domestic and commercial applications. Designed and made in Italy this fan is quiet to run and has a streamlined, minimal and discreet design with its slimline flat cover.



MANUFACTURER:



WARRANTY:

2 years

INSTALLATION:

- Wall or ceiling mounted, use in conjunction with an external grille, and may be used with rigid or flexible ducting (not included)
- Works with short ducting lengths (up to 3m)
- Suitable for domestic or commercial single room applications including:
 - Bathrooms and powder rooms
 - Laundries
 - Portable buildings and classrooms
 - Small offices and meeting rooms
 - Utility rooms
- Installation by an industry professional (electrician or air-conditioning installer) is recommended

BENEFITS:

- Innovative European slim line design with flat cover and lateral intake
- Easy to install
- Supplied with back-draught shutters to prevent air from moving back into the room
- Quiet operation – innovative impellers permit limited noise level
- Maintenance free – self lubricating sleeve bearing motor for long life & noiseless operation
- Made of high quality antistatic tecnopolymer material
- Comes in 3 sizes moving 90 – 315m³ of air per hour

ELEGANCE

Wall /ceiling fan

APPLICATIONS:

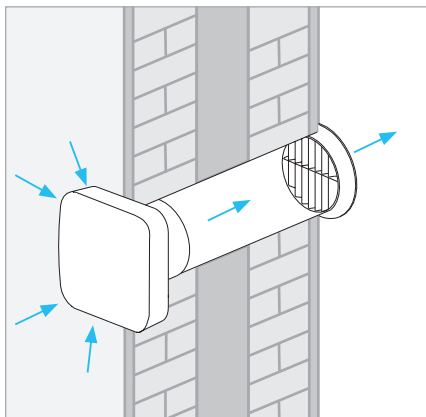

Wall

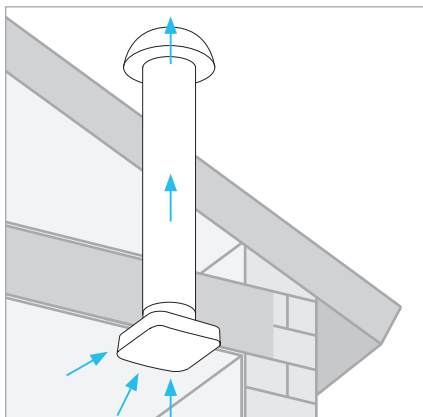

Ceiling

SPECIFICATIONS:

| Model | Item Code | Volume m ³ /h (maximum) | Volume L/s (maximum) | Pressure (maximum) | Wattage | Noise dB(A)* | Protection |
|--------------|-----------|------------------------------------|----------------------|--------------------|---------|--------------|------------|
| Elegance 100 | 2EL0000 | 90 | 25 | 42 | 14 | 31.4 | IPX4 |
| Elegance 120 | 2EL2500 | 165 | 46 | 55 | 15 | 36.7 | IPX4 |
| Elegance 150 | 2EL5000 | 315 | 87 | 71 | 25 | 43.9 | IPX4 |

* Measured at 3 metres

DIMENSIONS:

| Model | A | ØB | C | D | Kg |
|--------------|-----|-----|-----|----|-----|
| Elegance 100 | 160 | 98 | 80 | 38 | 0.9 |
| Elegance 120 | 180 | 119 | 91 | 44 | 1.1 |
| Elegance 150 | 200 | 149 | 105 | 56 | 1.3 |

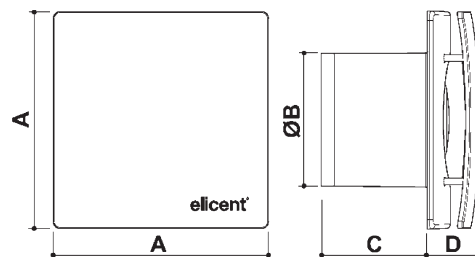

PERFORMANCE:

